

E75C / E110 Condensing Boiler

Standard Features

- Onboard outdoor reset control system with sensor standard
- Prebuilt plumbing kit with insulated Low Loss Header
- Priority DHW standard
- Built in DHW plate heat exchanger
- Domestic hot water plate warming
- Modulating Ceramic premix burner
- 5:1 turn down ratio
- Spark ignition
- Exceeds SCAQMD 1146.2 Low NO_x requirements
- Stainless Steel Water tube condensing heat exchanger
- Direct Vent sealed combustion
- Concentric and twin pipe venting adapters included
- Approved for room and closet installations

Optional Accessories

- RS100 Single zone controller
- Flue Gas temperature sensor
- Room Air Filter
- NG to LP conversion Kit
- LP to NG Conversion Kit

SPECIFICATIONS

General Specifications			
	Units	Boiler Model	Boiler Model
		E75C	E110C
Water content	gal	0.9	1.3
Max. supply boiler temperature	°F	176	176
Max operating pressure	psi	45	45
Relief valve rating	MBH	375	375
Relief valve pressure rating	psi	30	30
Dry weight	lbs	91	101
Min inlet gas pressure NG	"W.C."	4.0"	4.0"
Max inlet gas pressure NG	"W.C."	10.5"	10.5"
Min inlet gas pressure LP	"W.C."	8.0"	8.0"
Max inlet gas pressure LP	"W.C."	14.0"	14.0"
Max equivalent exhaust vent length	ft	100	100
Max equivalent combustion air vent length	ft	100	100
Approved venting materials		Polypropylene, Stainless Steel, PVC, CPVC	

Performance Specifications			
	Units	Boiler Model	
		E75C	E110C
Fuel Type		NG/LP	NG/LP
Input	MBH	75	110
Heating Capacity	MBH	69	101
AFUE (I=B=R)	%	96.5	96.1
Part Load Efficiency (EN677)	%	98.8	99.0
DHW flow rate 75°F ΔT	gpm	2.1	3.2

Electrical Specifications			
	Units	Boiler Model	
		E75C	E110C
Electrical Voltage Mains	V/Hz	120/60	120/60
Electrical Voltage Controls	V	24	24
Power Consumption Max Load	W	145	145
Power Consumption Stand by Load	W	14	14
Recommended Circuit breaker rating	A	15	15

Rinnai is continually updating and improving products; therefore, specifications are subject to change without prior notice. Local, state, provincial and federal codes must be adhered to prior to installation.

DIMENSIONS

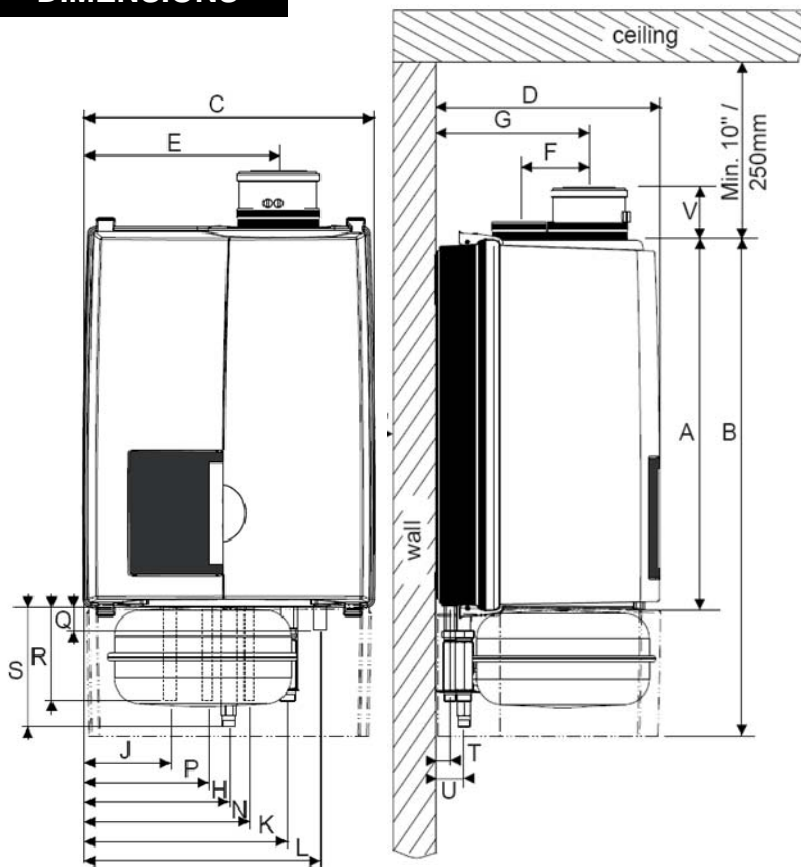

		E75C	E110C
		inch / mm	
A	Height	25.6 / 650	
B	Height with expansion tank	NA	34.3 / 870
C	Width	19.7 / 500	
D	Depth	15.6 / 395	
E	Left side / vent	13.2 / 335	
F	Center to center / vent and air supply	4.7 / 120	
G	Back / vent	10.6 / 270	
H	Left side / gas pipe	9.8 / 250	
J	Left side / supply pipe	5.9 / 150	
K	Left side / return pipe	13.8 / 350	
L	Left side / condensate pipe	15.9 / 405	
N	Left side / cold water pipe	11.2 / 285	
P	Left side / hot water pipe	8.5 / 215	
Q	Pipe length of g	0.7 / 19	8.5 / 215
R	Pipe length of c	1.6 / 40	
S	Pipe length of f, k, r, and w	2 / 50	6.3 / 160
T	Back / center of pipe c, k, and w	1 / 26	
U	Back / Center of pipe f, g, and r	2 / 50	
V	Pipe length vent co-axial Pipe length vent parallel	3.7 / 95 7 / 177	

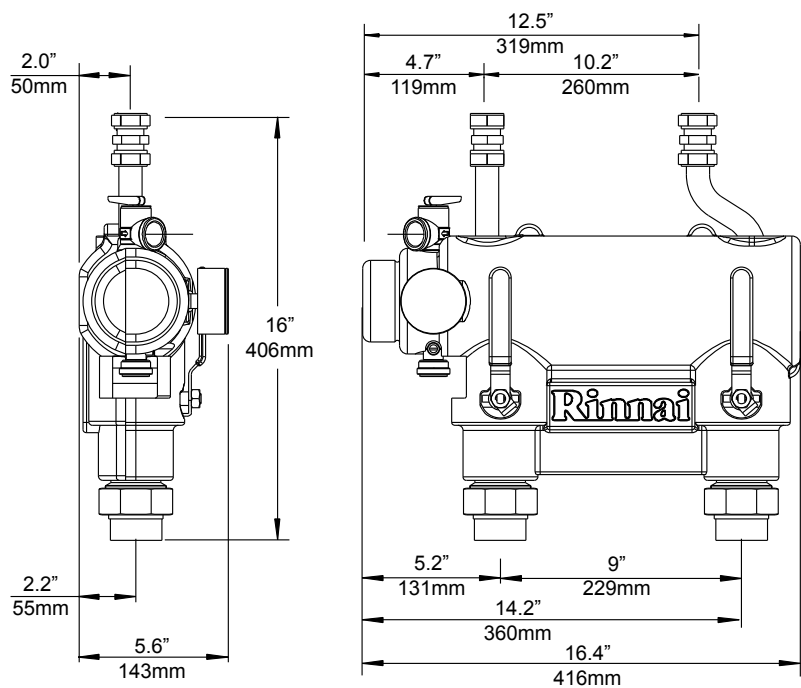

Clearances

	Minimum required clearance to combustibles and non-combustibles	Recommended service clearances
	inch / mm	inch / mm
Top	2 / 50	10 / 250
Back	0	0
Front	6 / 150	24 / 600
Left side	2 / 50	2 / 50
Right side	2 / 50	2 / 50
Floor / Ground	12 / 300	30 / 762
Vent	0	0